

REV.	ECN. NO.	APPD.
A	ECN131115015	Fan Fang
B	ECN131225033	Fan Fang

- NOTES:
- 1.DIMENSION SHALL BE INTERPRETED PER ASME Y14.5M-1994.
 - 2.ELECTRICAL CHARACTERISTICS
 - 2.1 CURRENT RATING:1.5A MAX.;
 - 2.2 CONTACT RESISTANCE:75 mOHMS MAX.;
 - 2.3 INSULATION RESISTANCE: 1000 MOHMS' MIN.;
 - 2.4 WITHSTANDING VOLTAGE: 500 VAC FOR 1 MINUTE MIN.;
 - 3.MECHANICAL CHARACTERISTICS
 - 3.1 DURABILITY:500 CYCLES
 - 3.2 VIBRATION:PASSED EIA-364-28.
 - 3.3 SHOCK:PASSED EIA-364-27H.
 - 4.ENVIRONMENT CHARACTERISTICS
 - OPERATION TEMPERATURE RANGE:-40°C TO +85°C .
 - 5.PLEASE CONTACT DRAPHO SALES REPRESENTATIVE TO VERIFY PRODUCT DETAILS & AVAILABILITY.
 - 6.HARMFUL MATERIAL CONTROL SHOULD MEET THE DOCUMENT "DSQC0042".

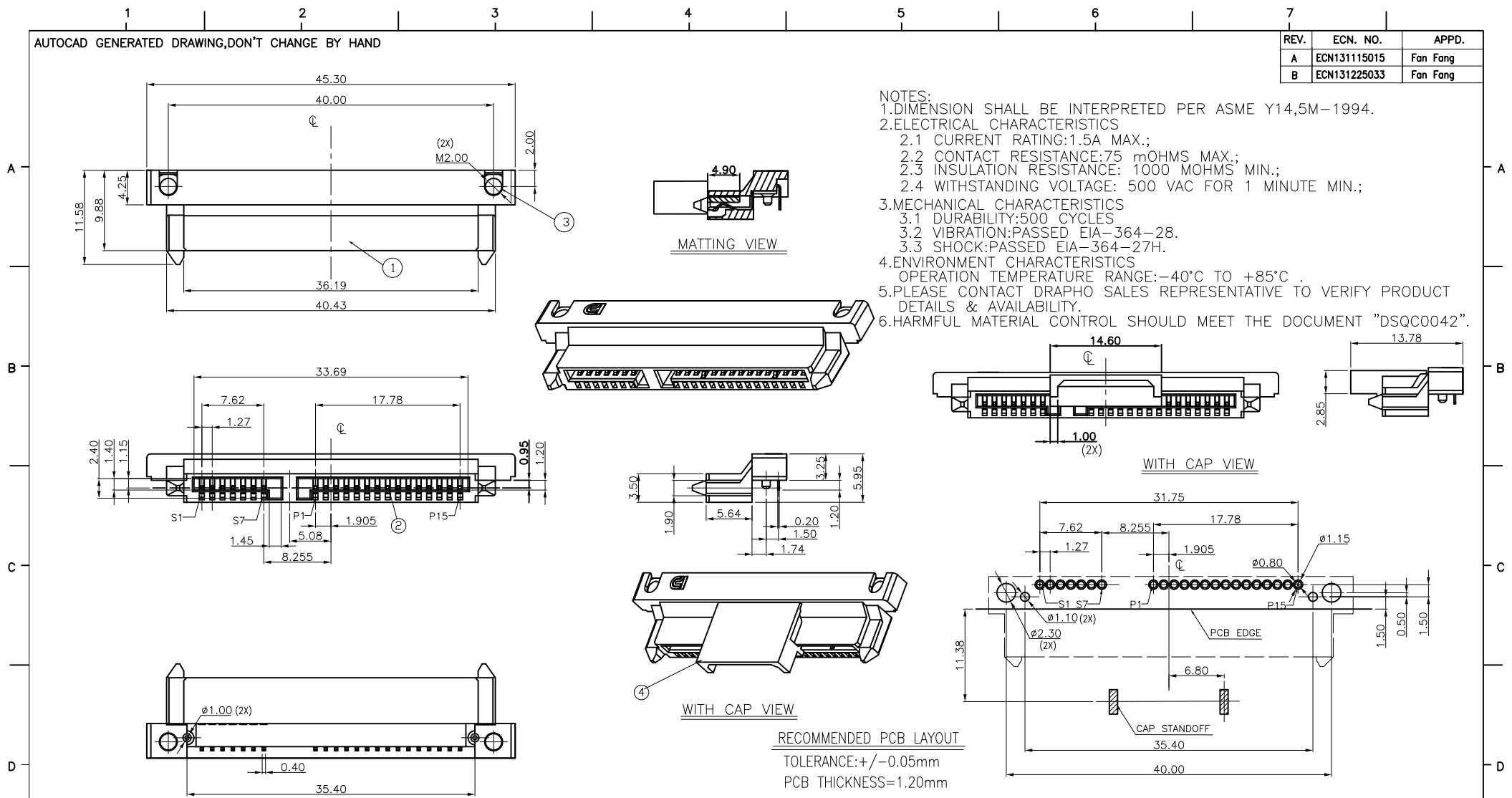

RECOMMENDED PCB LAYOUT
 TOLERANCE: +/-0.05mm
 PCB THICKNESS=1.20mm

PART LIST

SA 2 S 022 6-1111H

SATA CONN. LEAD FREE & HALOGEN FREE
 PITCH: 1.27mm

POS.NO. CONTACT AREA PLATING
 022:22 POS. 6: 1 u" GOLD PLATING

1	CAP	HIGHTEMP-PLASTIC	UL94V-0,BLACK	④
2	NUT	COPPER ALLOY	50u" NICKEL PLATING OVERALL.	③
22	CONTACT	COPPER ALLOY	50u" NICKEL UNDER PLATING; 1u" GOLD PLATING ON CONTACT AREA; 80u" MATTE TIN PLATING ON SOLDER AREA.	②
1	HOUSING	HIGHTEMP-PLASTIC	UL94V-0,BLACK	①
Q'TY	NAME	MATERIAL	FINISH	ITEM NO.
UNITS: mm	GENERAL TOLERANCE		APPROVED: Fan Fang	PART NO.(INTENDED USE) SA2S0226-1111H
DATE: 12/25'13	X. ±0.30 .X ±0.20	X* ±5.00* .X* ±3.00*	CHECKED: Walker Zhao	TITLE: SATA CONNECTOR
SCALE: N/A	.XX ±0.15	.XX* ±2.00*	DRAW: Adam Zhu	DRAWING NO.: 820-0000-106
SHEET: 1/2	MATERIAL:	Q'TY	Highstar Drapho ELECTRONICS TECHNOLOGY CO., LTD	
REV.: B	FINISH:			



REV.	ECN. NO.	APPD.

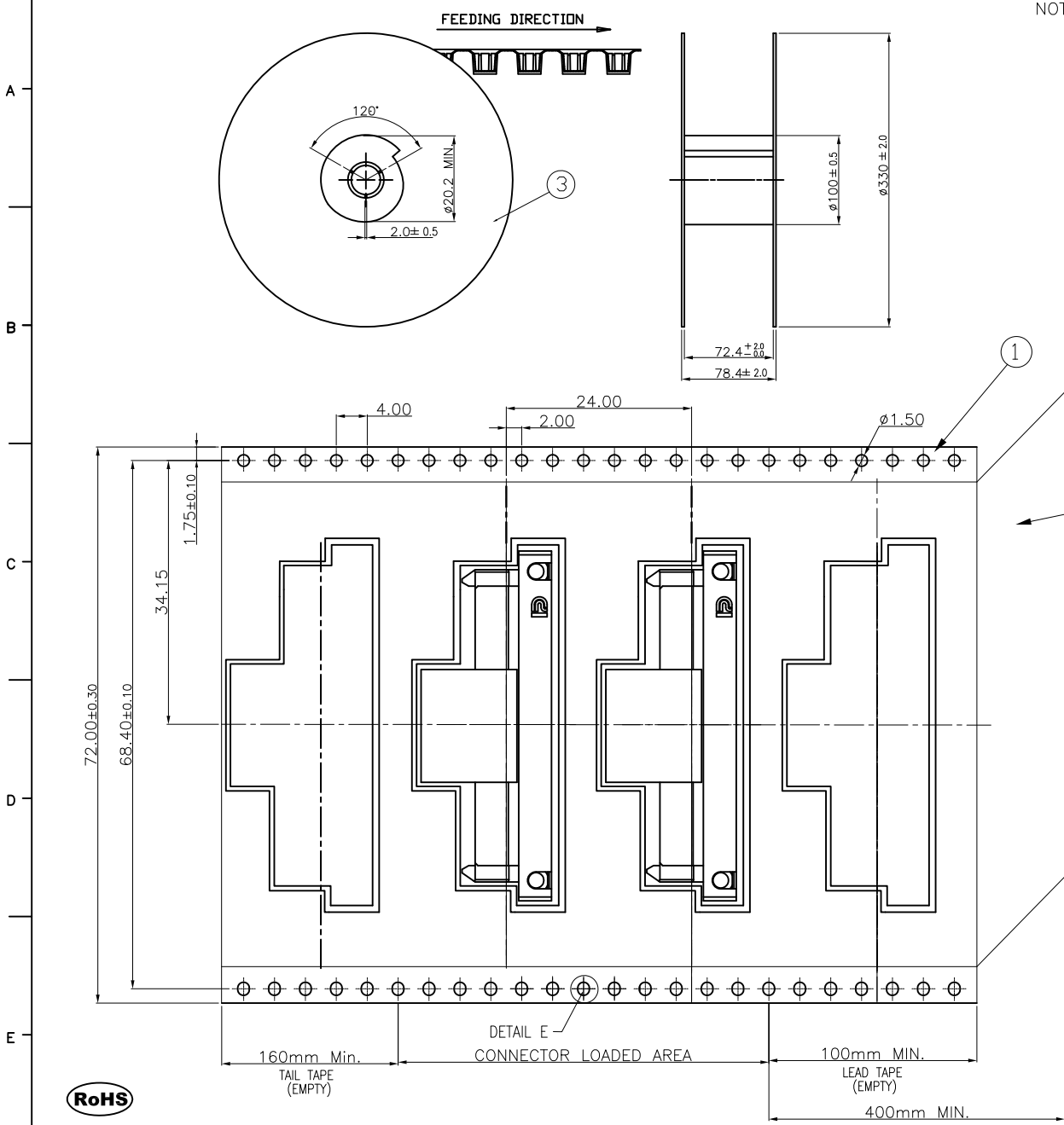

NOTES:
 1. 10 PITCHES CUMULATIVE TOLERANCE ON TAPE ±0.20mm.
 2. COVER TAPE PEELING STRENGTH: 0.13kgf MAX AT 300mm/MINUTE.

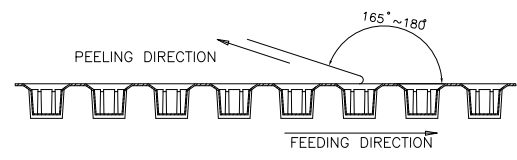

3. PACKING CAPACITY:

P/N	PCS/REEL	REEL/BOX	PCS/BOX
SA2S0226-1111H	400	4	1600

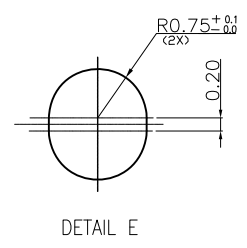

ITEM	DESCRIPTION
③	REEL
②	COVER TAPE
①	CARRIER TAPE

UNITS: mm	GENERAL TOLERANCE	APPROVE: Fan Fang	PART NO.(INTENDED USE) SA2S0226-1111H
DATE: 12/25'13	X. ±0.30 .X ±0.20 .XX ±0.15	CHECKED: Walker Zhao	TITLE: SATA CONNECTOR
SCALE: N/A	X.' ±5.00' .X' ±3.00' .XX' ±2.00'	DRAW: Adam Zhu	DRAWING NO.: 820-0000-106
SHEET: 2/2	MATERIAL: Q'TY	 Highstar	
REV.: B	FINISH:		

